

EXPERT REPORT

- Ordered by:** **Industria Espanola para Desarrollo e Investigacion 2100 (IEdISA)**
P.I. Poliviso – c/Panaderos,
41520 El Viso del Alcor, Sevilla - SPAIN
- Device under Test :** Shielding Paint “*Graphenstone Proshield*”
- Subject:** Shielding-measurements against electromagnetic waves from 100 MHz to 4,5 GHz and from 500 MHz to 18 GHz
- Regulations:** ASTM D-4935-2010 (American Society of Testing and Materials)
IEEE 299 – 2006 (similar to MILSTD 285)
- Date of Measurements:** 27th of September 2017
- Contents:** 5 pages of text, 2 pages with 2 measured diagrams
- Results:** The shielding paint “*Graphenstone Proshield*” presents the following shielding effectiveness at some interesting frequencies, especially at some mobile phone and W-LAN-frequencies:

Measured in a coaxial TEM-Adapter according to ASTM D-4935-2010 with E-vectors in all directions	200 MHz VHF-TV DAB	900 MHz GSM 900	1800 MHz GSM 1800	2450 MHz UMTS / W-LAN
	33 dB	30 dB	30 dB	31 dB

Measured according to IEEE 299-2006 with vertically polarized waves	450 MHz TETRA	900 MHz GSM 900	1800 MHz GSM 1800	2450 MHz UMTS / W-LAN	5,8 GHz New W-LAN
	33 dB	32 dB	30 dB	30 dB	27 dB

A value of 30 dB means, that 99,9% of the incident power is removed by shielding. Only 0,1% of the Power will penetrate the shielding paint. This is a very good shielding effectiveness, provided the thickness of the paint layer is equal to that of the test specimen.

1 Introduction

To explain the measured diagrams, it is helpful to use the table at the bottom. You can easily calculate the relation between shielding in „dB“ and transmitted power in „%“.

The network analyzer presents the results of the shielding measurements in „Decibel“ (dB). The mode of measurement is a typical transmission measurement (S₂₁-measurement). This dB value describes, how much the level of an incident power or power flux density has decreased, passing the device under test.

It describes values of field-strengths as well. But the calculation of the percent-values in the table at the right refers to the **power-relationships**. So it tells - for example - that 20 dB shielding reduces the penetrating power to 1%.

Conversion of Decibel to Percent of transmitted Power			
dB	Power Transmission in %	dB	Power Transmission in %
0	100,00		
1	81,00	21	0,78
2	62,80	22	0,63
3	50,00	23	0,50
4	40,00	24	0,39
5	31,60	25	0,31
6	25,00	26	0,25
7	20,00	27	0,20
8	16,00	28	0,18
9	12,50	29	0,12
10	10,00	30	0,10
11	7,90	31	0,08
12	6,25	32	0,06
13	5,00	33	0,05
14	4,00	34	0,04
15	3,13	35	0,03
16	2,50	36	0,02
17	2,00	37	0,02
18	1,56	38	0,02
19	1,20	39	0,02
20	1,00	40	0,01
		50	0,001

To calculate the dB-value from the incident power P₁ and the transmitted power P₂ , one has to use the following equation:

$$a_{\text{Shield}} = 10 \cdot \log \frac{P_2}{P_1}$$

2 Measurement Setup

2.1 Set-up according to IEEE-STD 299-2006

The measurements according to IEEE-STD 299-2006 (which is close to the MIL-Standard 285) were carried out in a shielded room of the Radar Laboratories at the German Armed Forces University Munich in Neubiberg as shown in Fig. 1 at frequencies from 500 MHz to 18GHz. Linear polarisation is radiated by logperiodic antennas or Exponential double-ridged horn antennas. The device under test is attached to a specific window as shown in the picture below (height 40 cm, width 40 cm). It was exposed to vertically polarized electromagnetic waves.

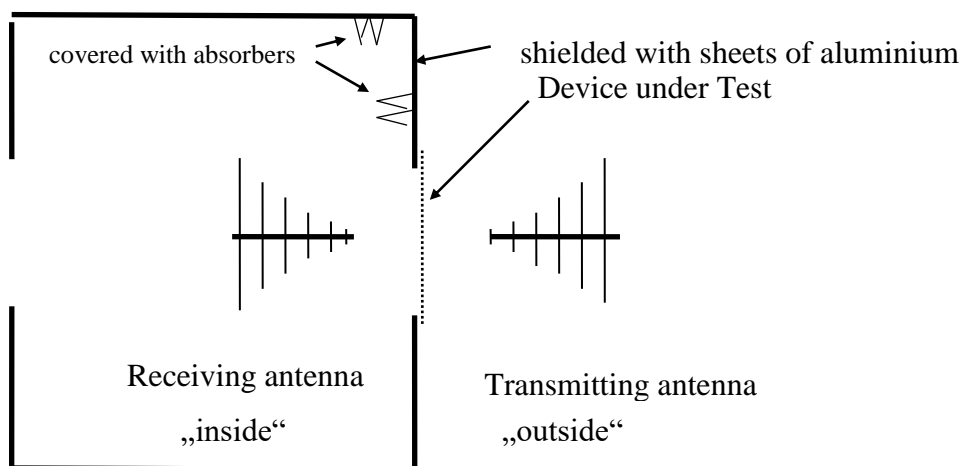

Fig. 1: Setup for Shielding Measurements

Test equipment:

Vector Network Analyzer type 360, Wiltron, 40MHz – 18,6GHz

Double-ridged horn antennas, type HF 906, Rohde & Schwarz, 1GHz – 18GHz

Documentation: Laser Printer Ecosys FS-1.4, Kyocera

2.2 Set-up according to ASTM D- 4935-2010

This standard was published by the American Society of Testing and Materials (ASTM) for three reasons:

1. To measure the shielding effectiveness also at „low“ frequencies.
2. To measure extreme high shielding.
3. To measure also relatively small devices under test.

The basic measurement is presented in the figure below:

The DUT is installed between two coaxial TEM-Adapter. The test signal comes from port 1 of a Network analyzer. The transmitted signal was received by port 2 of the NWA. Due to the coaxial structure with a TEM-wave, the DUT is hit by E-field vectors in all directions. The consequence is: If the measured shielding is very good, you can assume, that the DUT will shield as well vertically as also horizontally polarized waves in the same quality.

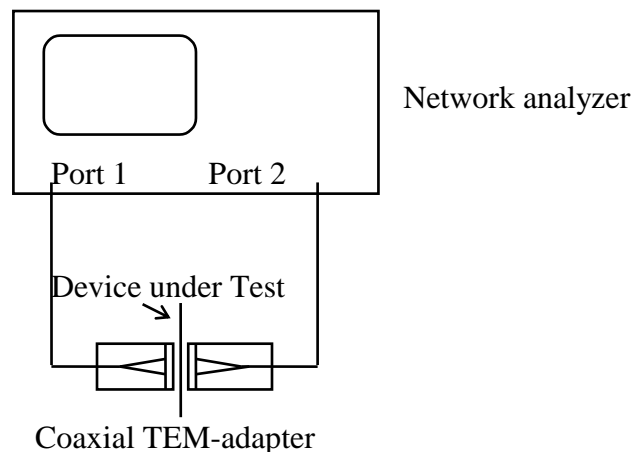

Fig. 2: Set-up to measure the shielding effectiveness in the MHz- und GHz-range

Test equipment:

Vector Network Analyzer type ZVRE (30 kHz – 8 GHz), Rohde & Schwarz
Coaxial TEM-Adapter, Wandel + Goltermann

3 Results of the measurements and comments

The diagrams present the transmission values in decibels as a function of frequency.

The vertical scale is: **10 dB/DIV**

The 0 dB-Reference line is the second **bold** line at the top of the diagrams.

On the right top of the diagrams one can read the measured shielding values at different frequency markers.

To find out, how many percent of the incident power is shielded, the table on page 2 presents the conversion between **dB** and **%** (of power).

The shielding paint “*Graphenstone Proshield*” presents the following shielding effectiveness at some interesting frequencies, especially at the most important mobile phone and W-LAN-frequencies:

Measured in a coaxial TEM-Adapter according to ASTM D-4935-2010 with E-vectors in all directions	200 MHz VHF-TV DAB	900 MHz GSM 900	1800 MHz GSM 1800	2450 MHz UMTS / W-LAN
	33 dB	30 dB	30 dB	31 dB

Measured according to IEEE 299-2006 with vertically polarized waves	450 MHz TETRA	900 MHz GSM 900	1800 MHz GSM 1800	2450 MHz UMTS / W-LAN	5,8 GHz New W-LAN
	33 dB	32 dB	30 dB	30 dB	27 dB

A value of 30 dB means, that 99,9% of the incident power is removed by shielding. Only 0,1% of the Power will penetrate the shielding paint. This is a very good shielding effectiveness, provided the thickness of the paint layer is equal to that of the test specimen. The slight differences in the results in the two tables depend on the different polarisations at the two measurement set-ups.

Device under test: Shielding paint *Graphenstone Proshield*
Frequency Range: 100 MHz to 4,5 GHz

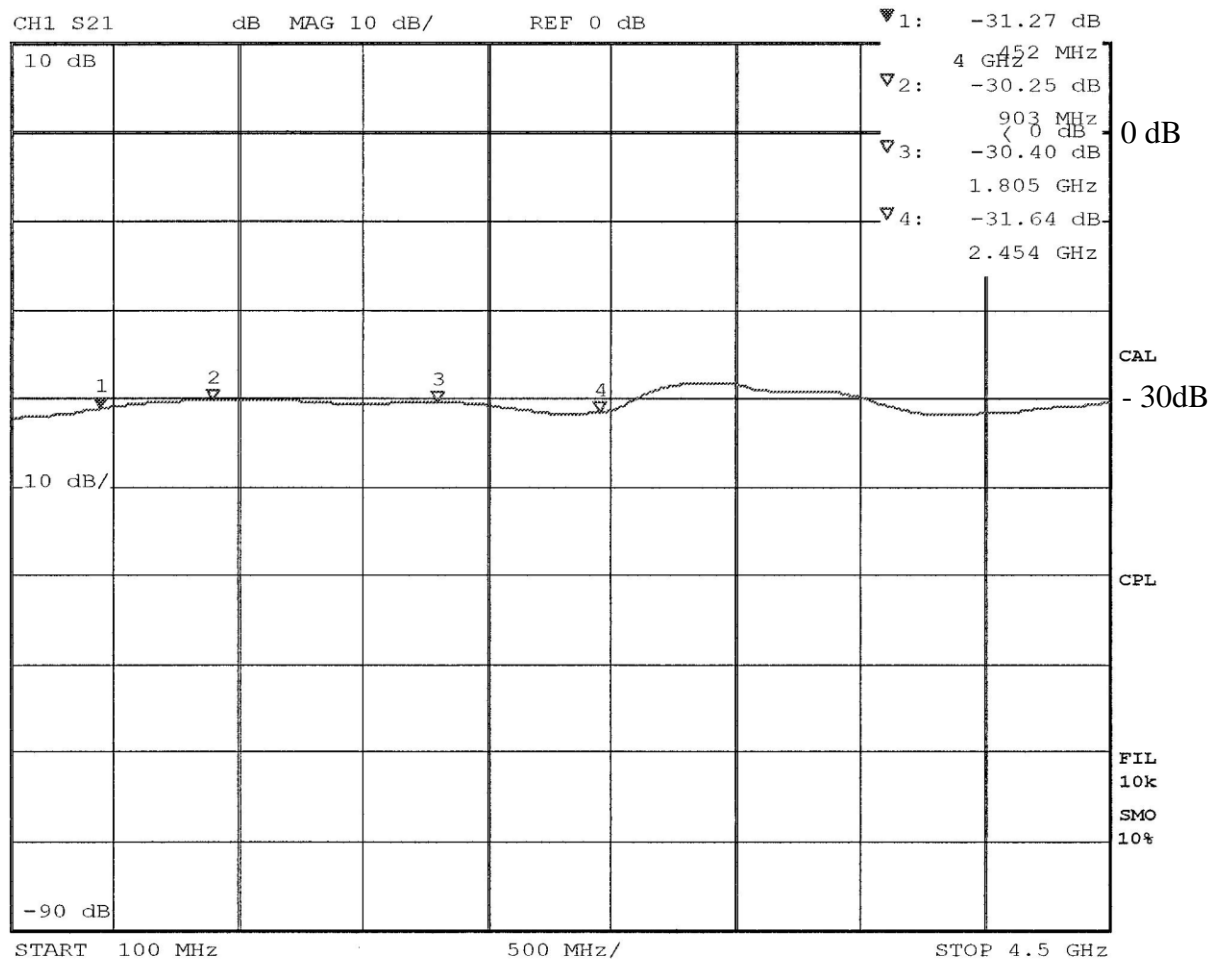

Device under test: Shielding paint *Graphenstone Proshield*
Frequency Range: 500 MHz to 18 GHz

